



مؤتمر ومعرض كهرباء الخليج 2017
GCC POWER 2017
16-18th OCTOBER 2017
Grand Millennium Muscat- Oman

THE 13TH GCC CIGRE INTERNATIONAL CONFERENCE
AND THE 22ND EXHIBITION FOR ELECTRICAL EQUIPMENT



Space Contract Form

SPACE & STANDFITTING REQUIREMENTS: (min. inside space 12 sqm)

Space Type	Cost	Space	Total
Space Only	US \$ 600 sqm	X sqm	
Shell	US \$ 800 sqm	X sqm	
Fitted Shell	US \$ 1000 sqm	X sqm	
Total		X sqm	

PAYMENT TERMS & METHOD

50% on application of any item above: \$ _____
 Balance due on September 1st, 2017: S _____

Payment can be made by *cheque or bank transfer*, as per the below details:

Name Of Beneficiary: GCC CIGRE
Account No. : 0104792920028
Bank: Qatar Islamic Bank (QIB) – Corporate Branch Grand Hamad Street
Abu Buhri St 1 - Al Najada -Doha-Qatar
Tel :(+974) 44409409, Fax: (+974) 44412700
SWIFT Code: QISBQAQA
IBAN:QA66QISB000000000104792920028

COMPANY DETAILS

Company Name: _____
 Address: _____
 Country: _____
 P.O. Box: _____
 Telephone: _____
 Fax: _____
 Email: _____
 Website: _____
 Stand Number: _____

SIGNED BY(To be completed by the Organizers)

Name: _____
 Position: _____
 Signature: _____ Date: _____

Shell Stand...

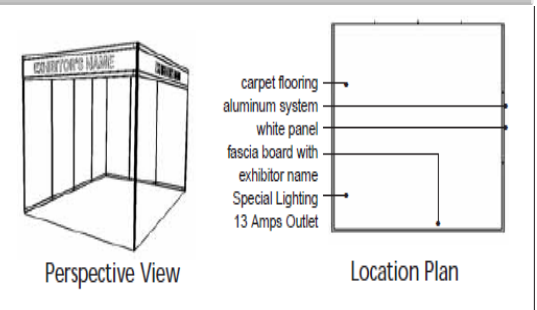

Fitted Shell

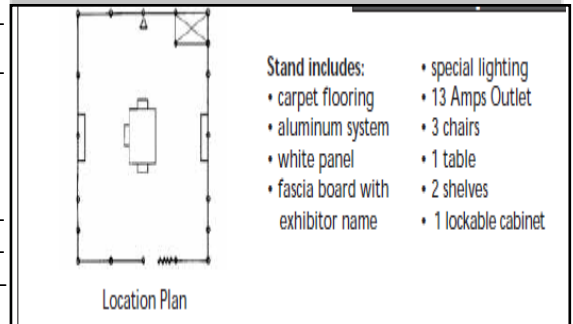

Please return this form by email to gsgccc@cigre-gcc.org, or by fax to: +974 44620474

General Terms & Conditions

1. Application for space in the Exhibition shall be made on the form overleaf and shall be duly signed by the Exhibitor or a person authorized by him. Following receipt of the Application together with initial payment, the Organizers reserve the right to refuse to accept any Application at their absolute discretion without giving reasons therefore.

2. The payment schedule for space only, shell stand or walk-on stand is as follows;

(i) 50% with submission of Application.

(ii) 50% balance by date specified on the Application.

Where the application is made after the final payment date specified on the Application, the total cost shall be payable with return of the Application. The total cost represents only the payment for the site, details of which are set out overleaf and all other goods and services required by the Exhibitor shall be paid for by the Exhibitor in addition thereto. Exhibitors will not be allowed to take over their space or stands if the payment terms specified on the Application are not followed.

These terms cannot be varied after the due date for payment until payment is made.

3. In addition to the space cost (and Organizers stand fitting service if applicable) Exhibitors will be billed for optional services such as hired furniture, electrics, telephones, directory advertisements etc.

4. In the event of the Organizers agreeing to any request for release from the Application, the Exhibitor will be liable for all, or part of the cost stated in the Application in accordance with the following scale:

➤ Cancellation, 90 days prior to the exhibition's opening date 50% OF TOTAL COST

➤ Cancellation, 60 days prior to the exhibition's opening date 70% OF TOTAL COST

➤ Cancellation, within the last 30 days prior to the exhibition's opening date 100% OF TOTAL COST

This scale of charges will apply only from the date the Organizers receive written notice by letter, fax or email. In addition to this scale, the Exhibitor will be liable for any specific cost incurred on his behalf by the Organizers. These terms cannot be varied under any circumstances.

5. Any organization which, having signed an Application for exhibition space, fails to exhibit for any reason of the Exhibitor's own choosing and has not been released from the Agreement by the Organizers shall be liable for the full amount stated in the Application plus any additional costs incurred by the Organizers as a result of such failure to exhibit.

6. In the event of any Exhibitor committing an act of bankruptcy or if a limited company being wound up the agreement terms with him shall be determined and all moneys already paid shall be retained by the Organizers.

7. The Organizers, their servants or agents shall not be liable for the safety of Exhibitors, their servants, agents, contractors or invitees during the Exhibition nor for any exhibits articles or other property of whatever kind brought into the Exhibition by Exhibitors, their servants, agents, contractors or invitees or members of the public.

8. All bookings are bound by these Terms and Regulations irrespective of any reservations which may be made. The Organizers reserve the right to alter, add to, or amend any of these conditions or not, the decision of the Organizers is binding if any disagreement on the interpretation of these regulations should arise.

9. Exhibitors shall make sure that they are fully covered by insurance including, but not restricted to, all risks on their property, exhibits or articles or any kind of public liability and comprehensive protection against any loss or damage caused by any circumstance whatsoever whether by reason of fire, water, theft, accident or any other cause. The Exhibitor shall insure against, indemnify and hold the Organizers harmless in respect of all costs, claims, demands and expenses to which the Organizers may in anyway be subject as a result of any loss or injury arising to any person (including members of the public or the Organizers' staff, agents or contractors) or property howsoever caused as a result of any act or default of the Exhibitor, his servants, agents or contractors or invitees. If the Organizers so demand the Exhibitor shall provide proof to the Organizers that the Exhibitor has adequate insurance cover. Exhibitors must ensure that their temporary staff and the staff of their servants, agents or contractors are insured against claims for workman's compensation. The period for which such insurance shall be maintained shall run from the time the Exhibitor or any of his servants, agents or contractors first enters the Exhibition grounds, and all his exhibits and property have been removed.

10. The Organizers shall not in any event be held responsible for any restrictions or conditions which prevent the construction, erection, completion, alteration or dismantling of stands or the entry, citing or removal of exhibits or for the failure or any services or amenities provided by the hall landlords or other third parties.

11. The contracted party for a group stand is responsible for ensuring that all Exhibitors within their group are fully aware of and agree to abide by these Terms and Conditions and by the Rules and Regulations of the exhibition as laid down in the Exhibition's Manual.

12. The Exhibitor must not transfer, dispose of, part with or otherwise sublet the whole or any part of his exhibition space, whether for financial consideration or otherwise. The Exhibitor must, if he is an agent, distributor or licensee, state at the time of Application the names of the principals to be represented. This does not prohibit an Exhibitor displaying the products of a principal for whom he becomes a distributor or licensee after the time of Application, with the prior written permission of the Organizers.

13. The Organizers shall not be liable to the Exhibitor by reason of any cancellation or part-time opening of the exhibition, either as whole or in part, for any non-performance of their obligations under this Application or any amendments or alterations to all or any of the Rules and Regulations of the exhibition in each case to the extent that such occurrence is due to any circumstances not within their control.

14. The Organizers have full power to allocate exhibition areas and position of exhibition space at the exhibition for any reason which in their sole opinion is in the general interest of the exhibition to alter the general layout or any particular stand even if already allotted and contracted and the Exhibitor shall accept such new allotment of space in substitution of that originally allotted to him.